

# NOT RECOMMENDED FOR NEW DESIGNS

\* For new designs please see part numbers: FR20DHIR FR20DVIR

## FM20VHIR FM20VVIR RedLink® Fiber Optic Receiver for Direct High Voltage Switching



### Preliminary Data Sheet



#### DESCRIPTION

This Firecomms RedLink® receiver is based on a fully integrated photodiode with TIA, limiting amplifier and a MOSFET open source output to handle switching of voltages in the range from 3 to 20 V (e.g. 3.3, 5, 12, 15 V). The part also includes an optional 1 kΩ pull up resistor  $R_L$ .

Housed in non-conducting plastic the RedLink® receiver connector is blue. The housings are compatible with the Versatile Link style of fiber plug and are optimized for use with Plastic Optic Fiber (POF).

The receiver operates over the industrial temperature range of -40 °C to +85 °C supporting many industrial applications where reliable command and control response is required in electrically harsh environments.

The receiver is typically used at low switching speeds where 12 V and 15 V power electronic devices are being switched at kHz speeds but can operate up to 5 MBd if required.

#### AVAILABLE OPTIONS

Package / Inverting, TTL	Part Number
5 MBd Horizontal Package Inverting, TTL	FM20VHIR
5 MBd Vertical Package Inverting, TTL	FM20VVIR



#### FEATURES

- Ideal for use with POF
- MOSFET output stage typically used to directly switch 12 V and 15 V thyristor gate devices.
- Optimized for data transmission from DC to 5 MBd
- Industrial temperature range -40 °C to 85 °C
- Flame retardant (UL 94 V-0) connector housings
- Fully integrated photodiode, TIA and limiting amplifier in a single IC
- 5 V TTL/CMOS compatible I/O for ease of design
- Integrated 1 kΩ pull up resistor to Vcc ( $R_L$ )
- Low pulse width distortion
- Compatible with Versatile Link cables and connectors

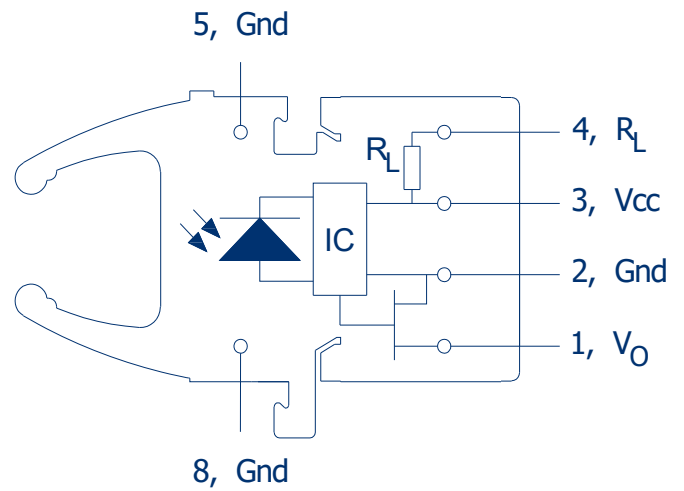
#### APPLICATIONS

Application	Switching of 20 V, 18 V, 15 V and 12 V thyristor gate drivers. Direct switching of SCR's and IGBT's
Distance	50 meters Step Index (SI) POF in typical operating conditions 30 meters in worst case conditions
Speed	DC to 5 MBd (depending on series resistance and load capacitance)

## SPECIFICATIONS

**Table 3**  
**RECEIVER PIN DESCRIPTION**

Pin	Name	Symbol
1	Receiver output	$V_O$
2	Receiver Ground	Gnd
3	Receiver Vcc	Vcc
4	$R_L$ pull up resistor	$R_L$
5	Retaining Pin	Gnd
8	Retaining Pin	Gnd



**FIGURE 1**  
Receiver pin-out, top view

**Table 4**  
**REGULATORY COMPLIANCE**

Parameter	Symbol	Standard	Level
Electrostatic Discharge, Human Body Model (contact ESD)	HBM	Mil-STD-883	Level 2 (4 kV)
UL Certification	UL	94 V-0	Files No. (Pending)
Storage Compliance	MSL	J-STD-020D	2a (4-week floor life)
Restriction of Hazardous Substances Directive	RoHS	Directive 2011/65/EU	Certified compliant

## RECOMMENDED APPLICATION CIRCUITS

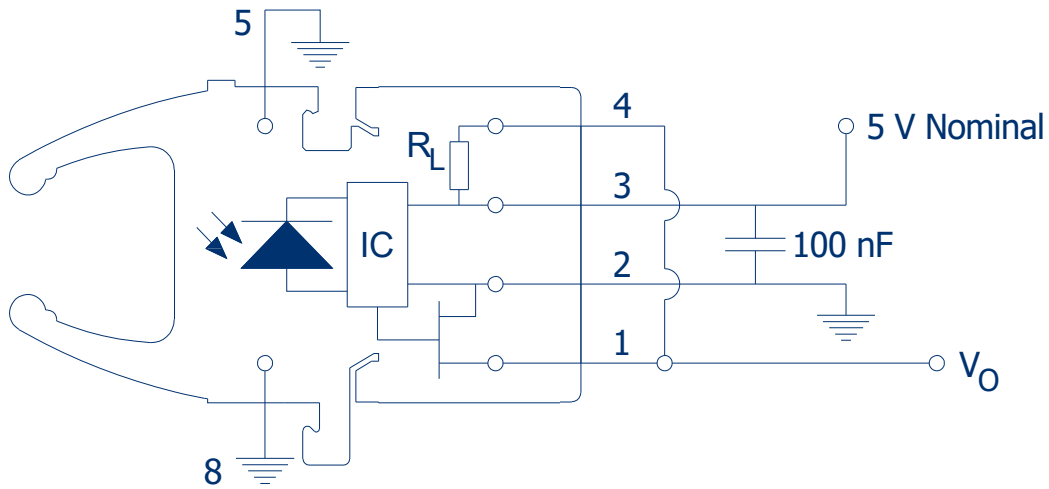


FIGURE 2  
RedLink® Receiver standard 5 V operation using RL pull-up resistor

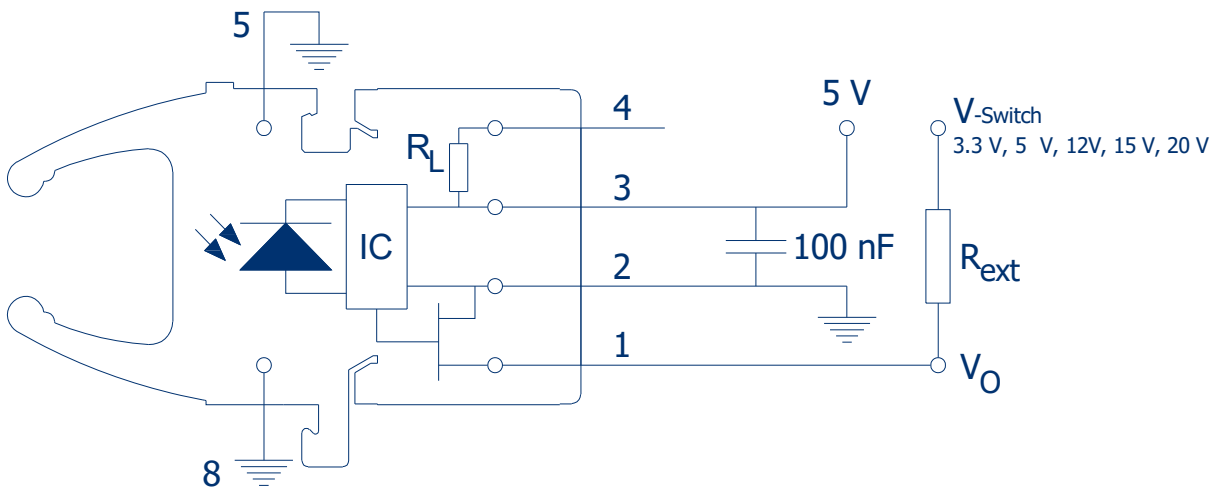


FIGURE 3  
RedLink® Receiver interface circuit for High Voltage (up to 20 V) switching. Typically used to switch 12 V and 15 V thyristor gates devices

## SPECIFICATIONS

**Table 5**  
**ABSOLUTE MAXIMUM RATINGS**

*These are the absolute maximum ratings at or beyond which the FOT can be expected to be damaged*

Notes:

1. 260 °C for 10 seconds, one time only, at least 2.2 mm away from lead root

Parameter	Symbol	Minimum	Maximum	Unit
Storage Temperature	$T_{stg}$	-40	+85	°C
Operating Temperature	$T_{op}$	-40	+85	°C
Soldering Temperature <sup>[1]</sup>	$T_{sld}$		+260	°C
Output Current (maximum drain source current)	$I_{FDC}$		±25	mA
Maximum Output Power	$P_{OD}$		40	mW
RX Supply Voltage	Vcc	-0.5	+5.5	V
Output Voltage	$V_o$	-0.5	20	V

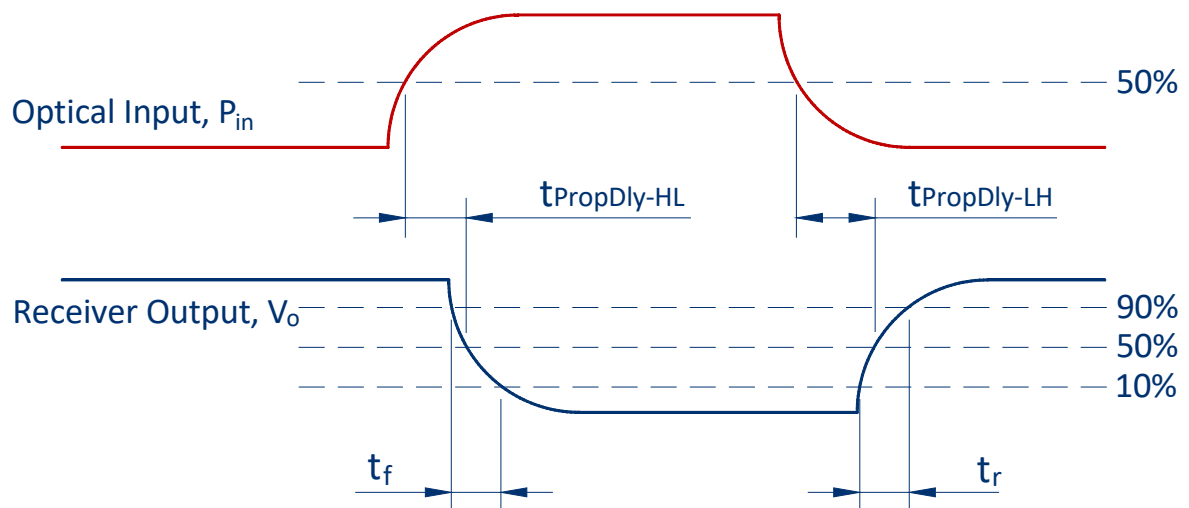


FIGURE 4  
Receiver Propagation Delay and rise/fall time definitions

## SPECIFICATIONS

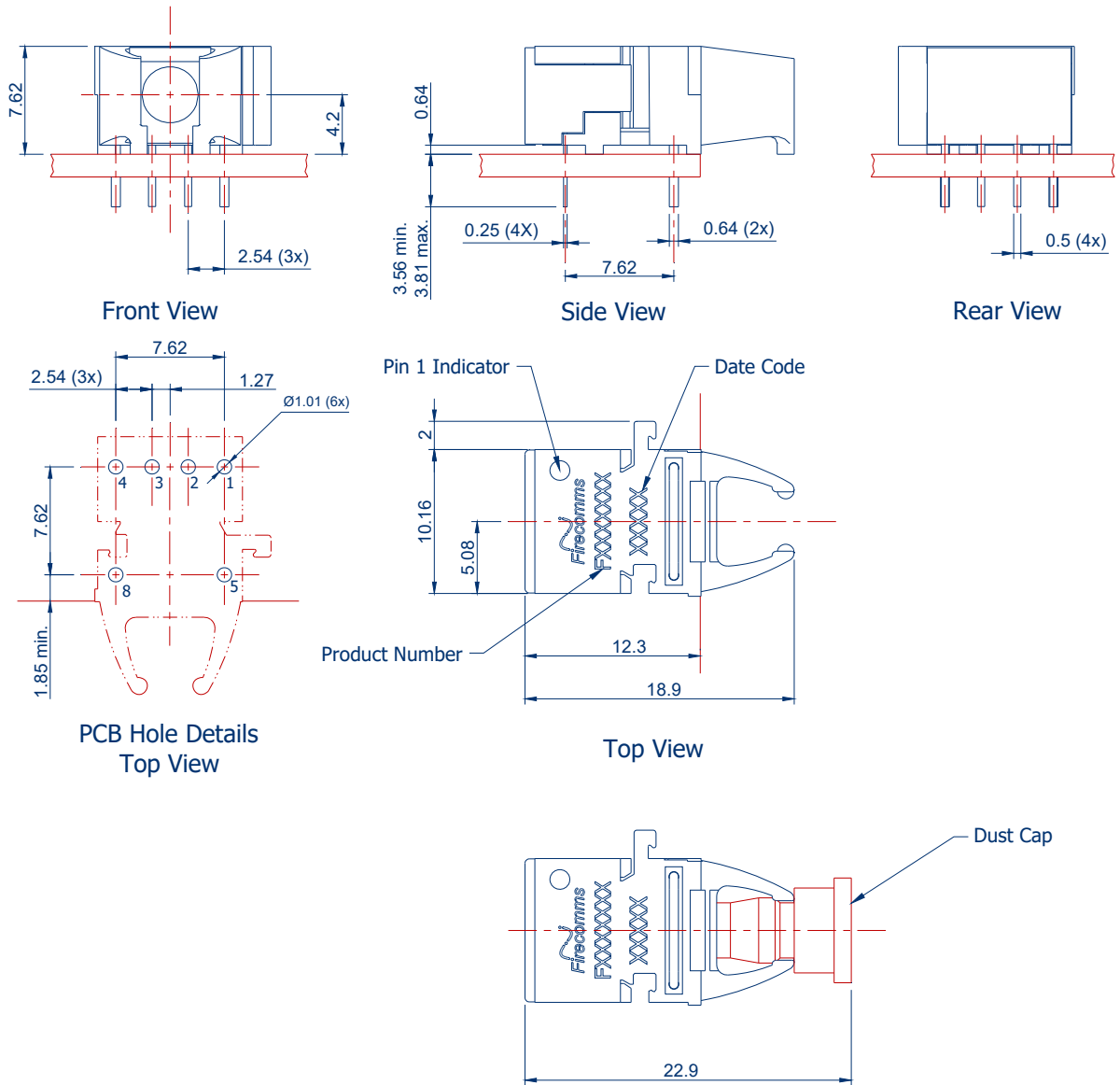
**Table 6**  
**RECEIVER ELECTRICAL AND OPTICAL CHARACTERISTICS**

*Test Conditions:*

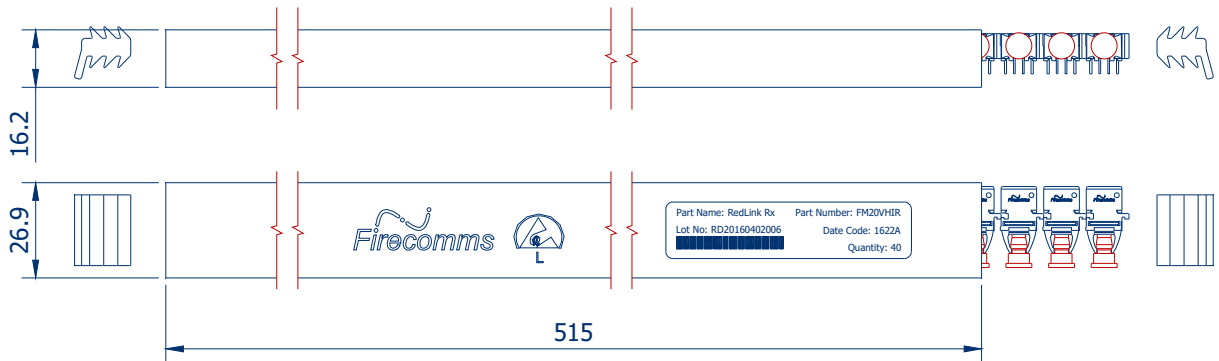
1. Test data was validated over the full temperature range of -40 °C to +85 °C, and over the full voltage range of 4.5 V to 5.5 V unless otherwise noted.  $P_{OPT} = -22$  dBm to -1 dBm. Typical data are at +25 °C with  $V_{CC} = 5$  V
2. Input power levels are for peak (not average) optical input levels. For 50% duty cycle data, peak optical power is twice the average optical power. Optical power for POF is measured when coupled into 0.5 m of a 1 mm diameter 0.5 NA POF and using a large area detector.
3. Pins 5 and 8 are used for mounting and retaining purposes only. Connect to ground.

Parameter	Symbol	Min	Typical	Max	Unit	Test Condition
Input Optical Power Level for Logic "0"	$P_{RL}$	-22		-1	dBm	
Input Optical Power Level for Logic "1"	$P_{RH}$			-43	dBm	
Applied Drain Voltage	$V_0$	3.3		20	V	$I_{O-max} = 25$ mA
Output Current	$I_0$			25	mA	Maximum DC value
Data Rate		DC		5	MBd	Min-UI = 200 ns, Max f = 2.5 MHz
High Level Input Current	$I_{OH}$		0.5	100	uA	$V_0=20$ V, Received Power < $P_{RH}$ maximum
Low level output Voltage	$I_{OL}$		44	75	mV	$I_{ol} = 25$ mA, Received Power > $P_{RL}$ minimum
Vcc Supply Current	$I_{CC}$	10.5	14.5	16	mA	
Rise Time (10% - 90%)	$t_r$	40	44	50	ns	Measured in the Interface Circuit for High Voltage, over the Vcc and V-switch range 4.5 V to 5.5 V, Ambient Temperature range -40 °C to 85 °C, Received optical power $P_H = -1$ to -22 dBm, at 5 Mbps. $R_{ext} = 560 \Omega$ , Cl- 22 pF. $R_L$ pin o/c.
Fall Time (90% - 10%)	$t_f$		3	5	ns	
1 <sup>st</sup> Pulse, Pulse Width Distortion	PWD-1 <sup>st</sup>		11	25	ns	
Pulse, Pulse Width Distortion	PWD		18	40	ns	
1 <sup>st</sup> Pulse Propagation Delay High to Low (OPTO-ELEC)	$t_{PropDly\_1st}$	30	42	70	ns	
Propagation Delay Low-to-High (OPTO-ELEC, Data/CLK)	$t_{PropDly\_LH}$	40	53	80	ns	
Propagation Delay High-to-Low (OPTO-ELEC, Data/CLK)	$t_{PropDly\_HL}$	15	34	65	ns	
Internal Pull Up Resistor to Vcc	$R_L$	700	1k	1300	$\Omega$	
Output Capacitance	$C_0$		11		pF	

### MECHANICAL DATA, HORIZONTAL

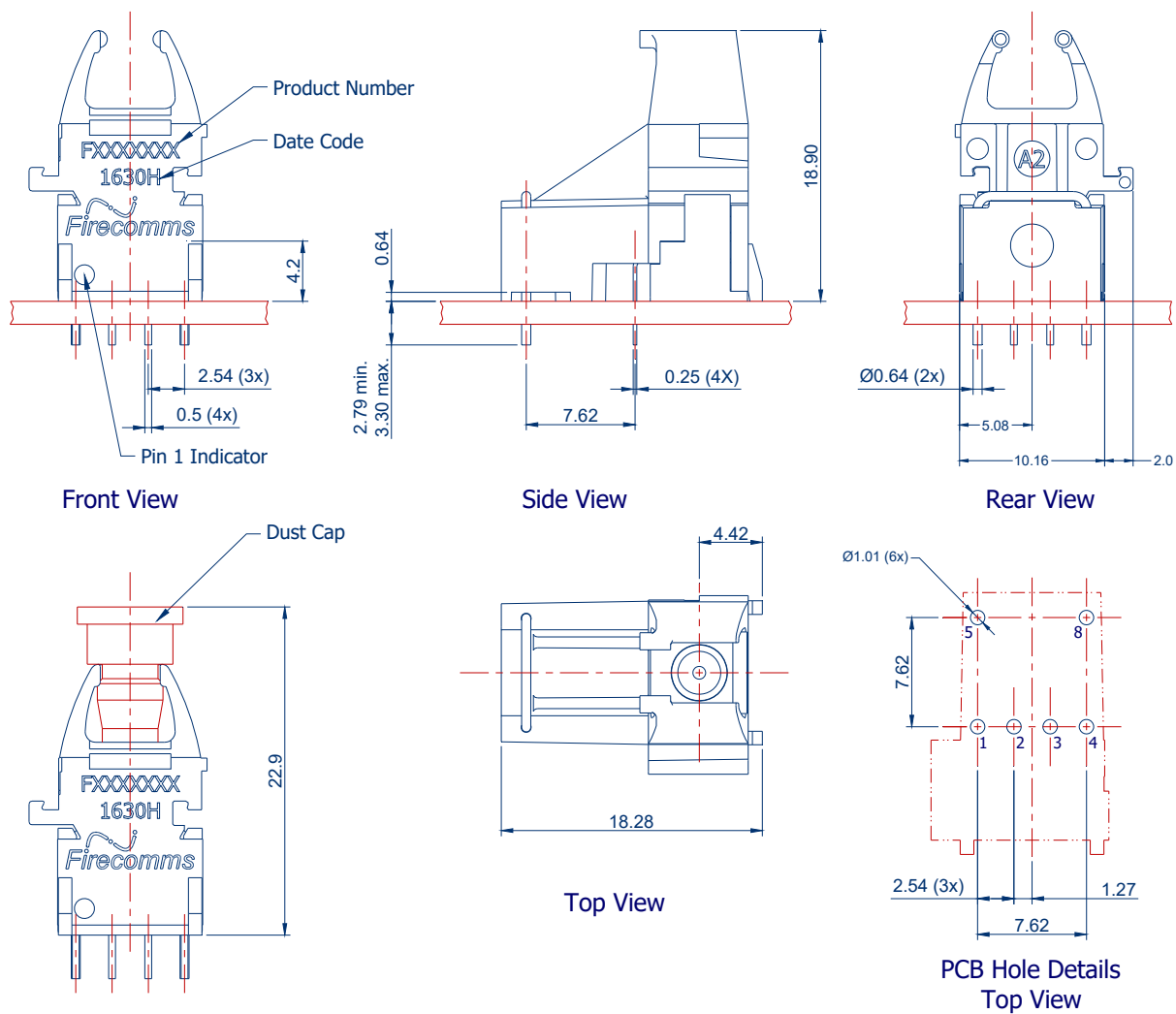


**FIGURE 5**  
 Mechanical dimensions of Firecomms Horizontal 20 Volt Switching RedLink® Receivers and PCB footprint, which is a top view. General dimensional tolerance is  $\pm 0.2$  mm

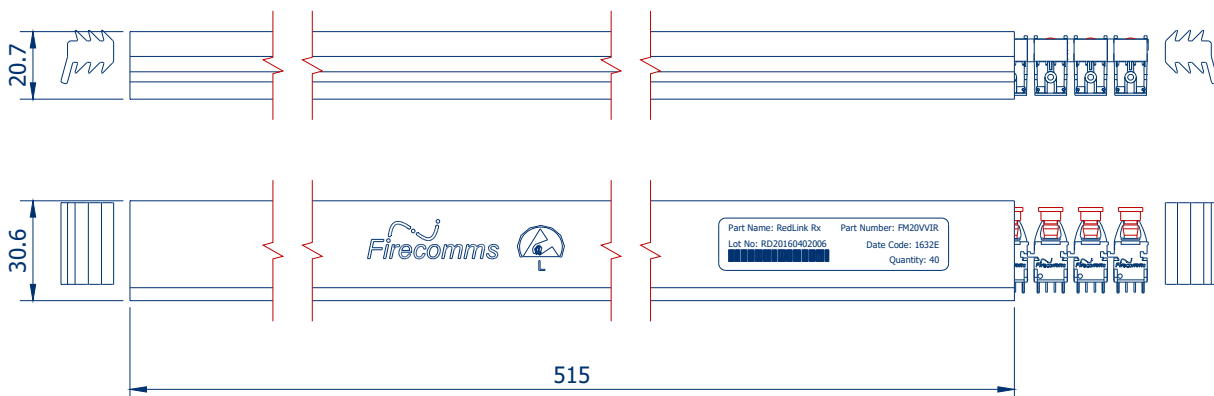


**FIGURE 6**  
 Packing tube for Firecomms Horizontal RedLink® Receivers

### MECHANICAL DATA, VERTICAL



**FIGURE 7**  
Mechanical dimensions of Firecomms Vertical 20 Volt Switching RedLink® Receivers and PCB footprint, which is a top view. General dimensional tolerance is  $\pm 0.2$  mm



**FIGURE 8**  
Packing tube for Firecomms Vertical RedLink Receivers

## PART HANDLING

The Firecomms high voltage RedLink® receiver devices are color coded blue. They are auto-insertable. They are tested for handling in static-controlled assembly processes (HBM). Cleaning, degreasing and post solder washing should be carried out using standard solutions compatible with both plastics and the environment. For example, recommended solutions for degreasing are alcohols (methyl, isopropyl and isobutyl). Acetone based product are not permitted.

In the soldering process, non-halogenated water soluble fluxes are recommended. RedLink® products are not suitable for use in reflow solder processes (infrared/vapor-phase reflow). The dust plug should remain in place during soldering, washing and drying processes to avoid contamination of the active optical area of each part.

The Moisture Sensitivity Level (MSL) classification of this device is 2a according to JEDEC J-STD-020E.

The shelf life of an unopened MBB (Moisture Barrier Bag) is 24 months at < 40 °C and < 90 % R.H.

Once the Moisture Barrier Bag is opened the devices can be either

- a) Stored in normal factory conditions < 30 °C and < 60 % R.H. for a maximum of 672 hours (4 Weeks) prior to soldering.
- b) Stored at < 10 % R.H. (Dry Cabinet).



## PACKING INFORMATION

Components are packed in PVC anti-static tubes in moisture barrier bags. Bags should be opened only in static-controlled locations, and standard procedures should be followed for handling moisture sensitive components.

**Table 7**  
**PACKING INFORMATION**

	<b>Horizontal</b>	<b>Vertical</b>
Components per Tube	40	40
Tube Length	515 mm	515 mm
Tube Height	16.2 mm	21.0 mm
Tube Depth	26.9 mm	30.8 mm
Tubes per Bag	5	5
Bags per Inner Carton	1	1
Inner Carton Length	630 mm	630 mm
Inner Carton Width	70 mm	70 mm
Inner Carton Height	105 mm	105 mm
Weight per Inner Carton, Complete	0.77 kg	0.92 kg
Components per Inner Carton	200	200
Inner Cartons per Outer Carton	10	10
Outer Carton Length	650 mm	650 mm
Outer Carton Width	235 mm	235 mm
Outer Carton Height	376 mm	376 mm
Weight per Outer Carton, Complete	8.14 kg	9.61 kg
Components per Outer Carton	2,000	2,000

For the most recent revision or further information please visit [www.firecomms.com](http://www.firecomms.com) or contact the company directly at the following address, Firecomms Ltd, 2200 Airport Business Park, Cork, IRELAND. Copyright© 2004-2016 Firecomms. All rights reserved. Firecomms refers to Firecomms Limited and/or its subsidiaries. Firecomms assumes no responsibility for inaccuracies or omissions in the information contained in this document. Specifications are subject to change without notice. No patent rights are granted to any of the circuits described herein.